

## OLT-10E8V

8-Port 10G EPON OLT

### Highlights



High Performance Chipset



100Gbps QSFP28 High-Speed Uplink



Compliant With IEEE 802.3ah and 802.3av

### Introduction:

SOFTTEL OLT-10E8V is a 8-Port 10G EPON OLT which is standardized in IEEE 802.3av and is evolved from the EPON standard IEEE 802.3ah. OLT-10E8V has good compatibility so that 10G EPON ONUs can coexist with EPON ONUs in an ODN. It is appropriate to be deployed in compact room environment. The OLT's can be used for FTTx networks, 5G wireless networks and other network environments.

OLT-10E8V provides 2\*GE(RJ45), 2\*10GE(SFP+), 2\*25GE(SFP28) and 2\*100GE(QSFP28) slots independent interface for uplink, and 8\*10G EPON ports for downlink(Maximum Split Ratio is 1:256).

### Interface of OLT-10E8V

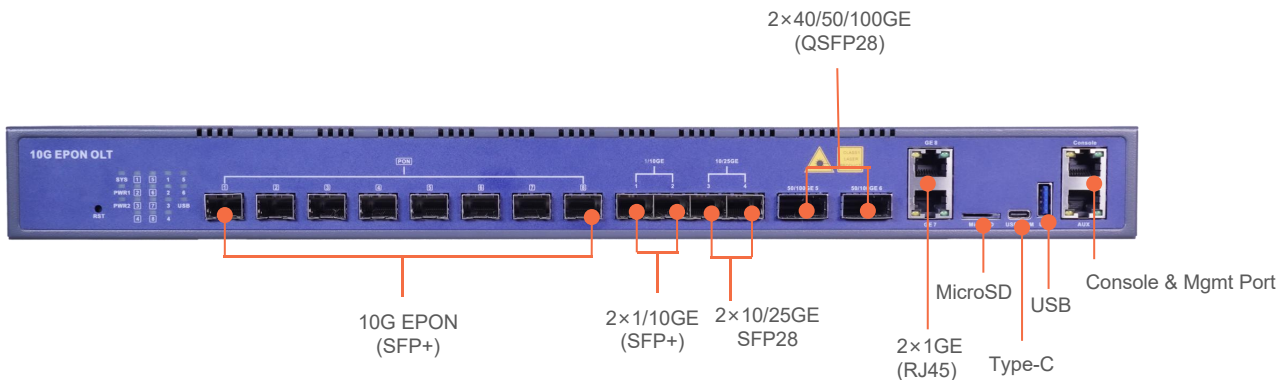

### Ordering Information:

Product Name	Product Description	Power Configuration	Accessories
OLT-10E8V	8*10G EPON, 2*GE(RJ45)+ 2*10GE(SFP+)+2*25GE(SFP28) +2*100GE(QSFP28)	1*AC power; 2*AC power; 1*DC power; 2* DC power; 1*AC power + 1* DC power.	10G EPON SFP+ PR30 module 10G EPON SFP+ PRX30 module 100GE QSFP28 module 25GE SFP28 module 10GE SFP+ module

# OLT-10E8V 8 Ports 10G EPON OLT

## Technical Specifications:

### Management Ports

- 1\*10/100BASE-T out-band port,
- 1\*CONSOLE port, 1 Type-C

### PON Port Specification

- Transmission Distance: 20KM
- 10Gbps 1577nm TX
- 1.25Gbps 1490nm TX
- 1.25Gbps 1310nm RX
- 10Gbps 1270nm RX
- Connector: SC/UPC
- Fiber Type: 9/125µm SMF

### Management Mode

- SNMP/Telnet/CLI/WEB/SSH v2/EMS

### Management Function

- Fan Group Control;
- Port Status monitoring and configuration management;
- Online ONU configuration and management;
- User management, Alarm management

### Layer 2 Feature

- 16K MAC address
- Support port VLAN
- Support 4096 VLANs
- Support VLAN tag/Un-tag, VLAN transparent transmission, QinQ
- Support IEEE802.3d trunk
- Support RSTP, MSTP
- QoS based on port, VID, TOS and MAC address
- IEEE802.x flow control
- Port stability statistic and monitoring
- Support P2P Function

### Multicast

- IGMP snooping
- 8K IP MulticastGroups

### DHCP

- DHCP server
- DHCP relay
- DHCP snooping

### Layer 3 Features

- ARP proxy
- Static route
- 4K hardware Host Routes
- 16K hardware Subnet Routes
- Support RIPv1/v2, OSPFv2
- Support PPPoE+

### Security Management

- Support IEEE802.1x, Radius, Tacacs+
- Support DHCP Snooping,DHCP Opiton82, IP Source Guard
- Support HTTPs, SSHv2

### IPv6 Feature

- Support IPv6 Neighbor Discovery, SLAAC Snooping
- Support DHCPv6 Server,DHCPv6 Relay,DHCPv6 Snooping
- Support IPV6 Static Route
- Support IPV6 Dynamic Route Protocol: RIPng,OSPFv3
- Support MLD V1/V2
- Support IPv6 ACL
- Support IPv6 SNMP, Telnet, HTTPs, SSH management

### EPON Function

- Support port-based rate limitation and bandwidth control
- In compliant with IEEE802.3ah, IEEE802.3av standard
- Support data encryption, multi-cast, port VLAN, separation, RSTP, etc
- Support Dynamic Bandwidth Allocation (DBA)
- Support ONU auto-discovery/link detection/remote upgrade of software
- Support VLAN division and user separation to avoid broadcast storm
- Support various LLID configuration and single LLID configuration
- Different user and different service could provide different QoS by means of different LLID channels
- Support power-off alarm function, easy for link problem detection
- Support broadcasting storm resistance function
- Support port isolation between different ports
- Support ACL to configure data packet filter flexibly
- Specialized design for system breakdown prevention to maintain stable system
- Support dynamic distance calculation on EMS online

Item		OLT-10E8V
Backplane Bandwidth (Gbps)		880
Port Forwarding Rate(Mpps)		523.776
Chassis	Rack	1U 19 inch standard box
Uplink Port	QTY	6
	1/10GE(SFP +)	2
	10/25GE(SFP28)	2
	40/50/100GE(QSFP28)	2
10G EPON Port	QTY	8
	Physical Interface	SFP+ Slots
	Connector Type	PR30/PRX30
	Max splitting ratio	1:256
Electric port	QTY	2
	Physical Interface	RJ45
	Rate	1000M/100M/10M, adaptive
Dimension (LxWxH)		442mm*369mm*46.6mm
Net Weight		3.9kg
Power Supply		AC 100~240 V, 50/60 Hz, 200W
DC Power Supply		DC: -48V
Power Consumption		≤145W
Operating Environment	Working Temperature	0~+50°C
	Storage Temperature	-40~+85°C
	Relative Humidity	5~90% (non-condensing)