

**Technical Specification**  
**Pre-connectorized Fiber Optic Cable Distribution Box**  
**SPD-16QX**

**Hangzhou Softel-Optic Co., Ltd.**

**All rights reserved**

<b>Customer Approval</b>			
	<b>Name</b>	<b>Signature</b>	<b>Date</b>
<b>Approved by</b>			

# Contents

1. General .....	2
1.1 Description .....	2
1.2 Standards Comply .....	2
1.3 Applications Environment .....	2
2. Characteristics .....	3
3. Specifications .....	3
3.1 Mechanical specifications .....	3
4. Configuration .....	4
4.1 Main optical parameters .....	4
5. Product Picture .....	4
5.1 Product cable ways: .....	4
5.2 Splicing tray .....	5
5.3 Accessories .....	7
6.Environmental characteristics .....	8
7. Installation: .....	8
7.1. Wall-mounted installation .....	8
7.2. Pole-mounted installation .....	8
7.3. The overhead structure .....	9
8. Connector operation .....	9
8.1 Pre-connected adapter - A ( E ) .....	9
8.2 Pre-connected adapter - B ( XL ) .....	9
8.3 Pre-connected adapter - C .....	10
8.4 Pre-connected adapter - D .....	10
8.5 Pre-connected adapter - E ( A ) .....	11
8.6 Pre-connected adapter - SC .....	11
9.Package .....	12

## 1. General

### 1.1 Description

Pre-connectorized optical distribution box as the most advanced FTTX network distribution node equipment, provide quick and reliable connection, good protection and management for the FTTX network.

Production type	Classification
SPD-16QX	Pre-connectorized fiber optic cable distribution box



Appearance of SPD-16QX

### 1.2 Standards Comply

The production offered by FTTXTECH are designed, manufactured and tested according to the standards as follows:

ITU-T G.652	Characteristics of a single-mode optical fibre
IEC 60794-1-1	Optical fibre cables-part 1-1: Generic specification-General
IEC 60794-1-2	Optical fibre cables-part 1-2: Generic specification-Basic optical cable test procedure

### 1.3 Applications Environment

Item	Value
Operation temperature	-40 °C~+65 °C
Installation temperature	-5 °C~+40 °C
Storage temperature	-40°C~+65 °C
Atmospheric pressure	70~106Kpa
Relative humidity	≤93%(+40°C)

# Technical Specification

Internal public

## 2. Characteristics

- 2.1. Advanced structure design, easy operation and reasonable routing.
- 2.2. Material: PP.
- 2.3. Moisture proof, waterproof, dust-proof, anti-aging.
- 2.4. Protection level up to IP68.
- 2.5. 1 oval optical cable entry, 2 branch optical cable entries and 16 pre-connected adapters.
- 2.6. 2 type splice trays optional.
- 2.7. Installation method: pole-mounted, aerial-mounted, wall-mounted.

## 3. Specifications

### 3.1 Mechanical specifications

Item	Specifications	Remark
External dimension(mm)	378*255*136(A*B*C)	
Installation hole position(mm)	215*266*239(D*E*F)	
Color	Black	Customizable
Size and quantity of optical cable hole	1 oval optical cable entry, 2 branch optical cable entries and 16 pre-connected adapters	
Capacity(Max)	48	Tray A ,12x4=48, 2 layers of heat-shrinkable splice protection sleeve.
	96	Tray C, 12x8=96, 1 layer of heat-shrinkable splice protection sleeve.
	128	Tray F, 16x8=128, 1 layer of heat-shrinkable splice protection sleeve.
	96	Tray D, Tray E, 24x4=96, 2 layers of heat-shrinkable splice protection sleeve.
	136	Max=7*F+1E=7*16+24=136
Micro PLC Splitter	1x2	Splitter size : 60x7x4mm.
	1x4	Can be installed in type A and type E splicing tray, 1 PC per splicing tray.
	1x8	Splitter size : 60x12x4mm.
	1*16	Can be installed in type A-1, and type E-1 splicing tray, 1 PC per splicing tray.
Into the largest cable diameter (mm)	≤18	* <b>Note:</b> Provide the type and diameter of the optical cable when purchasing, to matching the appropriate sealing plug to ensure the sealing performance.
Maximum size of bifurcation hole (mm)	≤18	
IP protection level	IP68	

# Technical Specification

Internal public

Flammability	HB(Conventional)	can be customized according to requirements
Neutral salt spray test (NSS)	48 h	

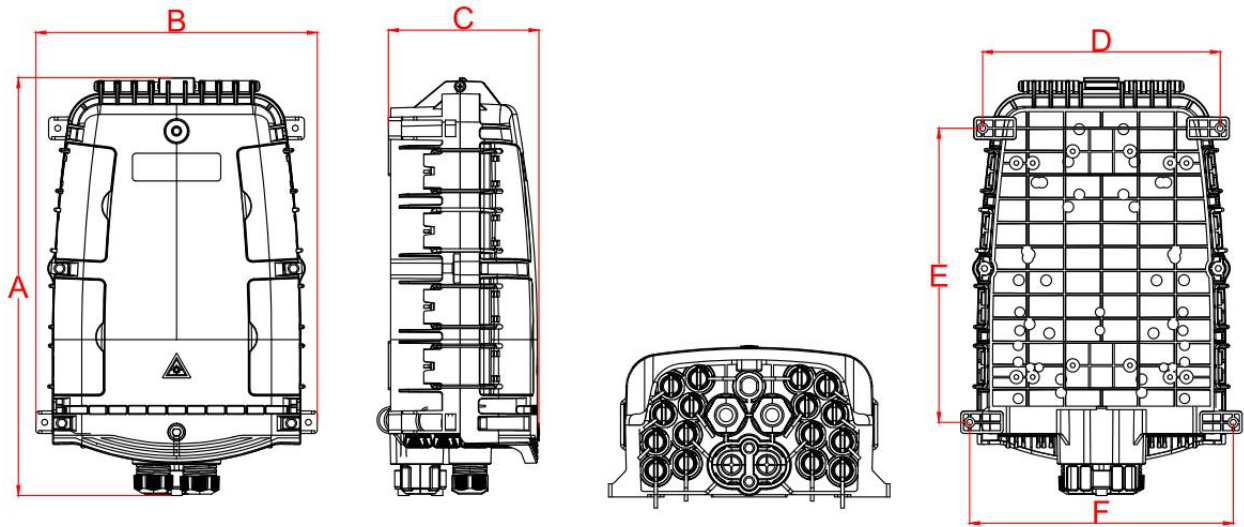

## 4. Configuration

### 4.1 Main optical parameters

Splitter or pigtail	IL(dB)	RL(dB)	IL(dB)	Test method
	Pigtail/Splitter		Distribution box	
Pigtail-SC/APC-00-SM-SX(1C1F)-OD0.9MM-PVC-G657A2-Cable Color(Default)-Indoor-RoHS-1.5m	≤0.3	≥55dB	≤0.5	IL: IEC61300-3-4 Method B RL: IEC61300-3-6 Method 1
1x2 PLC Splitter, with SCAPC connector	≤4.0	≥55dB	≤4.2	
1x4 PLC Splitter, with SCAPC connector	≤7.4	≥55dB	≤7.6	
1x 8 PLC Splitter, with SCAPC connector	≤10.5	≥55dB	≤10.7	
1x 16 PLC Splitter, with SCAPC connector	≤13.5	≥55dB	≤13.7	

The optical parameters shown in the table above are default values, and can be customized according to requirements.

## 5. Product Picture

### 5.1 Product cable ways:



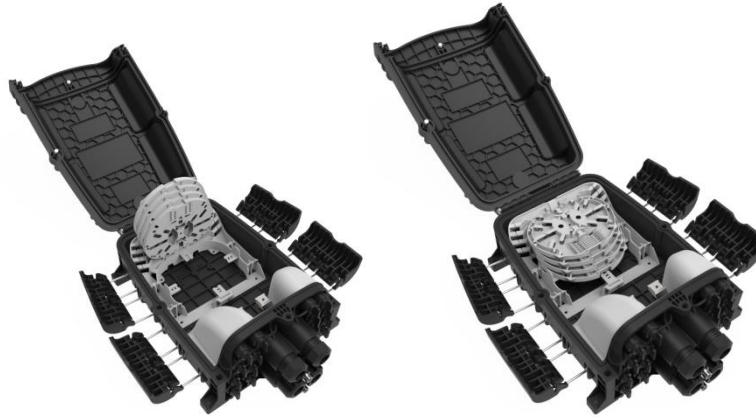
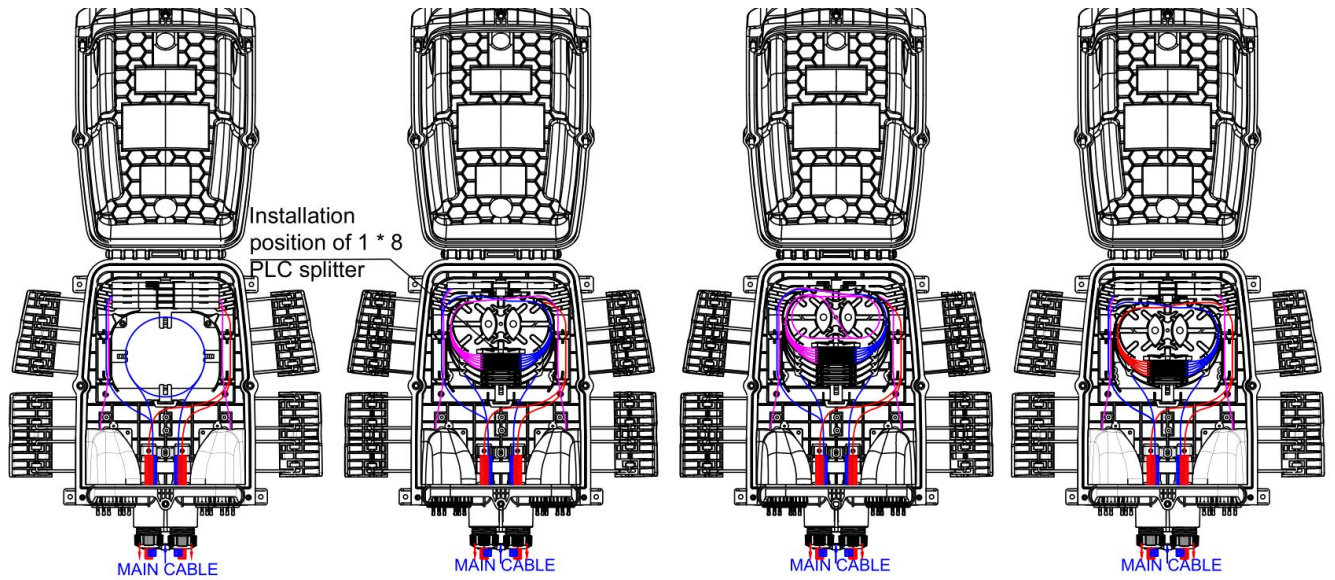

# Technical Specification

Internal public



SPD-16QX routing diagram





## 5.2 Splicing tray

Item	Splicing tray A	Splicing tray B	Splitter tray A-1	Splicing tray C
Dimensions(H*W*D, mm)	134*104*8	134*104*4	134*104*8	136 * 104 * 4
Net weight (kg)	0.021	0.015	0.021	0.018
Picture				
Color	RAL7035	RAL7035	RAL7035	RAL7035
Material	PC+ABS	PC+ABS	PC+ABS	PC+ABS
Splicing capacity of a tray(cores)	12 (2 layers of heat shrinkable protective sleeve)	8 (1 layer of heat shrinkable protective sleeve)	6 (2 layers of heat shrinkable protective sleeve)	12 (1 layer of heat shrinkable protective sleeve)

# Technical Specification

Internal public

Splitter capacity of a tray(PCS)	1 (PLC 1X2, 1X4, 1X8, 0.9mm fiber,60x7x4mm)	/	1 (PLC 1X16, 0.9mm fiber,60x12x4mm)	/
Maximum(PCS)	4	8	4	8
Default(PCS)	2	/	/	2
Note: 1. The above trays can be mixed according to requirements. 2. Configuration rules: 1A=2B=2C=1D=1E=2F 3. The types of fiber discs are increasing continuously				

Item	Splicing tray D	Splicing tray E	Splicing tray E-1	Splicing tray F
Dimensions(H*W*D, mm)	136 * 104 * 8	135 *125*8	135 *125*8	135 *125*4
Net weight (kg)	0.024	0.033	0.033	0.021
Picture				
Color	RAL7035	RAL7035	RAL7035	RAL7035
Material	PC+ABS	PC+ABS	PC+ABS	PC+ABS
Splicing capacity of a tray(cores)	24 (2 layers of heat shrinkable protection sleeve)	24 (2 layers of heat shrinkable protection sleeve)	18 (2 layers of heat shrinkable protection sleeve)	16(1 layer of heat shrinkable protective sleeve)
Splitter capacity of a tray(PCS)	/	1 (PLC 1X2, 1X4, 1X8, 0.9mm fiber,60x7x4mm)	1 (PLC 1X16, 0.9mm fiber,60x12x4mm)	/
Maximum(PCS)	4	4	4	8
Default(PCS)	/	/	/	/
Note: 1. The above trays can be mixed according to requirements. 2. Configuration rules: 1A=2B=2C=1D=1E=2F 3.The types of fiber discs are increasing continuously				

# Technical Specification



Internal public

## 5.3 Accessories

No.	Part name	Reference picture	Unit	Quantity	Remark
1	Users' manual	/	pcs	1	EN
2	Splitter test report	/	pcs	1	EN
3	Key		pcs	1	"D" type
4	Heat-shrinkable protection sleeve		pcs	16	L=45mm, Optional as customer's request
5	Nylon cable tie		pcs	10	3x100mm
6	Bare fiber protection tube		pcs	1	OD5mm x 50cm
7	Wall-mounted kit		set	1	Optional as customer's request. (Expanded plastic plug $\Phi 7.5 \times 40$ mm, Phillips self-tapping screws M5x40mm.)
8	Hoop		pcs	2	$\varnothing 13-19$ mm
9	Optical cable entrance sealing plug		pcs	2	
10	Brach cable sealing nut wrench		pcs	1	
11	M6 Allen key		pcs	1	M6
12	Pole-mounted kit-A		set	1	Optional as customer's request

# Technical Specification

Internal public

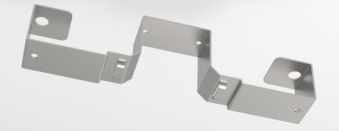
13	Pole-mounted kit-B		set	1	Optional as customer's request
14	Aerial-mounted kit		set	1	Optional as customer's request
15	Drop cable storage tray		pcs	2	Optional as customer's request

## 6.Environmental characteristics

This product complies with the RoHS environmental protection directive, and the content of lead, cadmium, mercury, hexavalent chromium, polybrominated biphenyl (PBB) and polybrominated diphenyl ether (PBDE) does not exceed the limit.

## 7. Installation:

### 7.1. Wall-mounted installation

Drill 4 holes in the wall according to the dimension in table 3.1, place the expansion plug  $\Phi 7.5 \times 40$ , place the box to match up the holes and use screws to fasten.

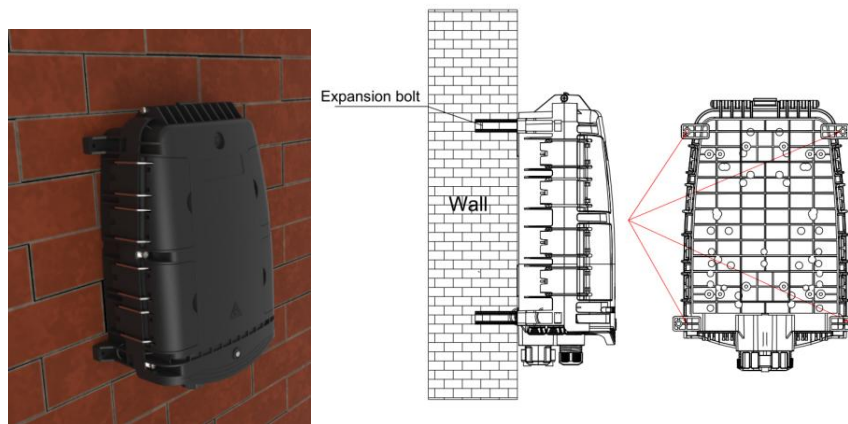

Wall mounted installation

### 7.2. Pole-mounted installation

Pass the hoop ring through the slot of the back plate and fix it on the telecommunication pole

# Technical Specification

Internal public

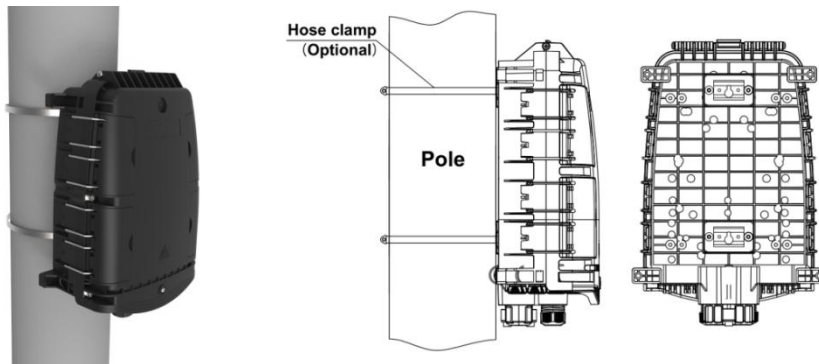

**Pole mounted installation**

## 7.3. The overhead structure

Tie the two installed on the chassis of the overhead hung on the wire, and then bolted, prevent the case fall off.

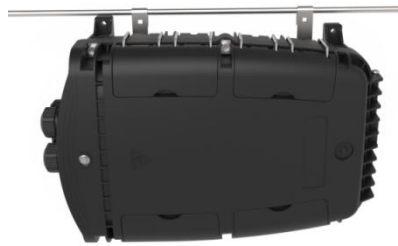

**The overhead structure**

## 8. Connector operation

### 8.1 Pre-connected adapter - A ( E )

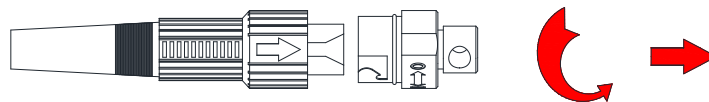

Rotate the arrow part of fiber connector counterclockwise and take out the dust cap.

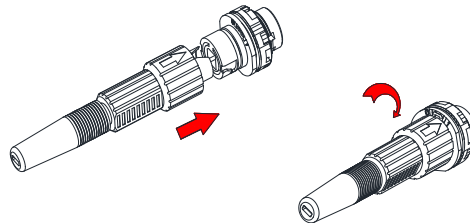

The arrow part of fiber connector is above, insert fiber connector into the socket and then rotate the arrow part clockwise.

### 8.2 Pre-connected adapter - B ( XL )

- Insert the SC optical fiber connector plug through the loose parts in turn, and then plug it into the adapter;
- Install XL pre connected adapter sheath on adapter with plastic key;

# Technical Specification

Internal public

- Insert the plug of the snap spring into the sheath;
- The cable clamp shall be installed and the line shall be close to the plug;
- Screw the leather cable clamp seat cap on the sheath clockwise.

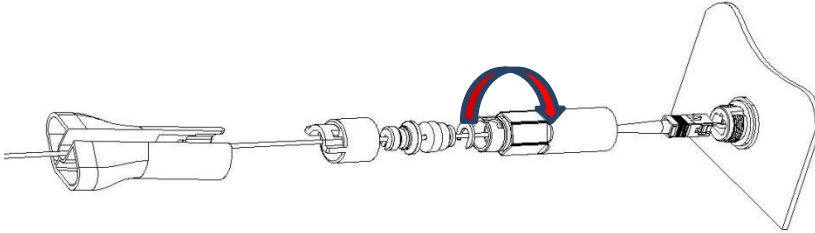

## 8.3 Pre-connected adapter - C

- Push the sliding ring on the optical fiber preformed plug in the direction of the arrow to remove the dust cap; press the button to take out the dust cap on the adapter in the direction of the arrow.



- Align the body of the preformed plug with the adapter buckle until it is fastened. Connect the two dust covers in the same way.



- The installed prefabricated plug pushes the sliding ring to release the buckle, and then pull the main body backward to separate it.



## 8.4 Pre-connected adapter - D

- Turn the pre connected plug anti clockwise and open the pre connected plug and dust cover in the direction of the arrow.

# Technical Specification

Internal public

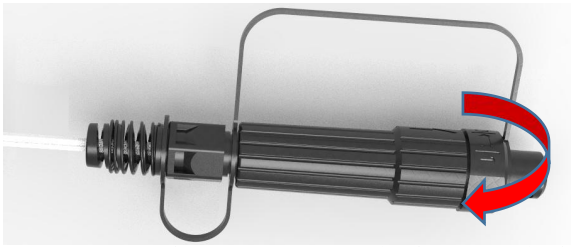

- Connect the pre connected plug D and the pre connected adapter D in the direction of the arrow, and rotate the plug clockwise to fix it.

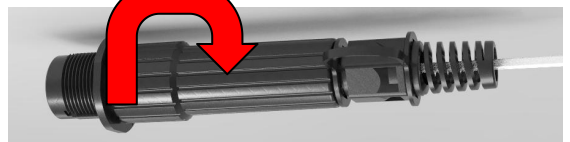
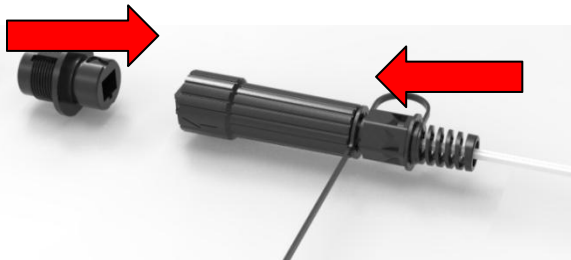

## 8.5 Pre-connected adapter - E ( A )

- Turn the pre connected plug anti clockwise and open the pre connected plug and dust cover in the direction of the arrow.

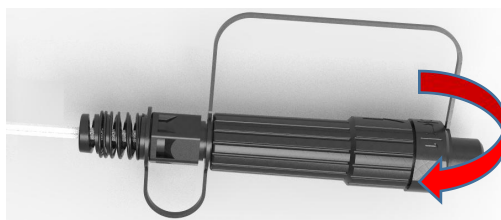

- Connect the pre connected plug E and the pre connected adapter E in the direction of the arrow, and rotate the plug clockwise to fix it.

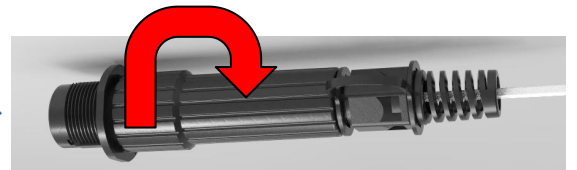

## 8.6 Pre-connected adapter - SC

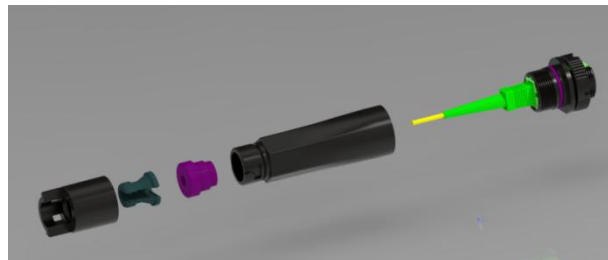

- Insert the SC optical fiber connector plug through the loose parts in turn, and then plug it into the adapter;

# Technical Specification

Internal public

- Install XL pre connected adapter sheath on adapter with plastic key;
- Insert the plug of the snap spring into the sheath;
- The cable clamp shall be installed and the line shall be close to the plug;
- Screw the leather cable clamp seat cap on the sheath clockwise.

## 9.Package

1PC in a bubble bag, 400\*480mm ;

1PC in a small carton, 385\*260\*150mm, gross weight is 3.5kg ;

8PCS in a big corrugated carton, 540\*405\*640 mm, gross weight is 29kg.