

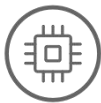

## XGSPON-08V

8-Port 10G Combo PON OLT

### Highlights



High Performance Chipset



100Gbps QSFP28 High-Speed Uplink



Supports XGS-PON/XG-PON/GPON triple mode

### Introduction:

SOFTTEL XGSPON-08V is an innovative 10G GPON OLT product with 8 PON ports and XG (S) - PON&GPON Combo compatibility. XGSPON-08V supports smooth upgrades from GPON to XG (S) - PON, achieving high bandwidth and high-speed data transmission to meet large-scale deployment requirements. This product has comprehensive management and monitoring functions, simplifies operation and maintenance processes, and provides rich business features and scalability. XGSPON-08V can build a 10G GPON network, providing excellent user experience and high-quality services to operators.

### Interface of XGSPON-08V:

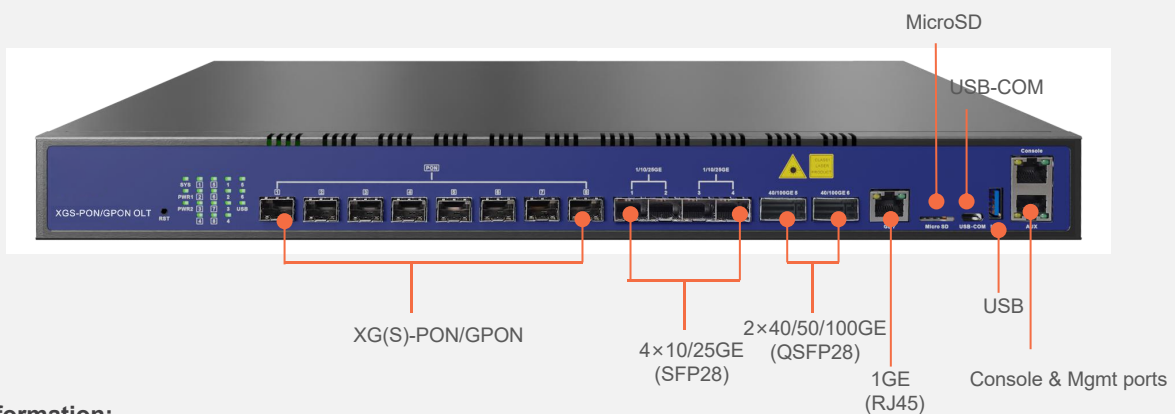

### Ordering Information:

Product Name	Product Description	Power Configuration	Accessories
XGSPON-08V	8*XG(S)-PON/GPON, 1*GE(RJ45)+ 4*25GE(SFP28)+2*100GE(QSFP28)	1*AC power; 2*AC power;	N2_C+ module 100GE QSFP28 module 25GE SFP28 module

# Technical Specifications

Item		XGSPON-08V
Chassis	Rack	1U 19Inch Standard Box
Uplink Port	QTY	8
	RJ45(GE)	1
	SFP28(25GE)	4
	QSFP28(25GE/50GE/100GE)	2
XG(S)-PON/GPON Port	QTY	8
	Physical Interface	SFP+ Slots
	Connector Type	N2_C+
	Optical Splitting Ratio	1:256(Maximum), 1:128(Recommended)
Management Ports		1*10/100/1000BASE-T out-band port, 1*CONSOLE port, 1*USB3.0, 1*Type-C USB console, 1*MicroSD port
Backplane Bandwidth (Gbps)		970
Port Forwarding Rate(Mpps)		598.176
XG(S)-PON/GPON Port Specification (N2_C+ module)	Transmission Distance	20KM
	XG(S)-PON Port Speed	GPON:Upstream1.244Gbps,Downstream 2.488Gbps XG-PON: Upstream 2.488Gbps, Downstream 9.953Gbps XGS-PON: Upstream 9.953Gbps, Downstream 9.953Gbps
	Wavelength	GPON:Upstream: 1310nm Downstream: 1490nm XG(S)-PON:Upstream: 1270nm Downstream: 1577nm
	Connector	SC/UPC
	TX Power	GPON:+3dBm ~ +7dBm XG(S)PON:+4dBm ~ +7dBm
	Rx Sensitivity	XGS-PON: -28dBm XG-PON: -29.5dBm GPON: -32dBm
	Saturation Optical Power	XGS-PON: -7dBm XG-PON: -9dBm GPON: -12dBm
Lightning Protection	Power Lightning Protection	6KV
	Interface Lightning Protection	4KV
Power Supply	AC	90-264 VAC, 47/63Hz
Number of Fans		4
Management Mode		CLI(Console/Telnet/SSH)/WEB

## Management Function

- SNMP, Telnet, CLI, WEB, SSH v2;
- Fan Group Control
- Port Status monitoring and configuration management
- Online ONT configuration and management
- User management
- Alarm management

## Layer2 Switch

- 32K Mac address
- Support 4096 VLANs
- Support port VLAN
- Support VLAN tag/Un-tag, VLAN transparent transmission
- Support VLAN translation and QinQ
- Support storm control based on port
- Support port isolation
- Support port rate limitation
- Support 802.1D and 802.1W
- Support static LACP, Dynamic LACP
- QoS based on port, VID, TOS and MAC address
- Access control list
- IEEE802.x flowcontrol
- Port stability statistic and monitoring

## Multicast

- IGMP snooping
- 2048 IP Multicast Groups;

## DHCP

- DHCP server, DHCP relay, DHCP snooping
- DHCP option82

## Layer 3 Route

- ARP proxy
- 4096 hardware Host Routes, 512 hardware Subnet Routes
- Support Radius, Tacacs+
- Support IP source guard
- Support static route, dynamic route RIP v1/v2, RIPng and OSPF v2/v3;

## IPv6

- Support NDP;
- Support IPv6 Ping, IPv6 Telnet, IPv6 routing;
- Support ACL based on source IPv6 address, destination IPv6 address, L4 port, protocol type, etc;
- Support MLD v1/v2 snooping

## PON Function

- T-CONT DBA
- x-GEM traffic
- In compliant with ITU-T G.9807(XGS-PON) and ITU-T G.987(XG-PON)
- Up to 20KM transmission Distance
- Support data encryption, multi-cast, port VLAN, separation, RSTP, etc
- Support ONT auto-discovery/link detection/remote upgrade of software

- Support VLAN division and user separation to avoid broadcast storm
- Support power-off alarm function, easy for link problem detection
- Support broadcasting storm resistance function
- Support port isolation between different ports
- Support ACL and SNMP to configure data packet filter flexibly
- Specialized design for system breakdown prevention to maintain stable system
- Support RSTP, IGMP Proxy

## Dimension (L\*W\*H)

- 442mm\*330mm\*43.6mm

## Weight

- Net weight : NA KG

## Power Consumption

- 150W

## Working Environment

- Working Temperature: 0°C ~+55°C
- Working Humidity: 10%~85%(non-condensing)

## Storage Environment

- Storage Temperature: -40 ~ +85°C
- Storage Humidity: 5%~95%(non-condensing)